

NAME _____

NUT CRACKER PLANS

Cross out steps as you complete them

1) Cut three squares at the **BAND SAW** using the miter gauge. Write name on all three pieces.

2) Stamp your 1st & last name on one of the squares.

Don't stamp name along the edges

3) Glue pieces together with grain going the same way at the gluing table.

MAKE SURE THE STAMPED NAME SQUARE IS ON BOTTOM

WAIT 5 MINUTES BEFORE GOING ON TO NEXT STEP

4) Clamp the 3 glued squares to your table using the portable clamp. Make sure that all the sides are even. Start with slight pressure. After 5 minutes tighten a little more, wipe off excess glue, and continue until Clamp is fully tightened.

LEAVE CLAMPED UNTIL THE LIGHTS GO OFF AND THEN GIVE TO KUHN

5) Sand all glue sides until smooth and no glue marks.

*****NOTE*****

BOTTOM has your name stamped on it, Top is the side opposite of the bottom and SIDES show the end grain

6) Draw a "X" on the top and draw an "X" on one of the sides (End grain)

FIGURE 1

7) On the top, draw a line with a tri-square through the center to the side with the "X" on it FIGURE 1 then measure up one inch from the side with the "X" on it. FIGURE 2

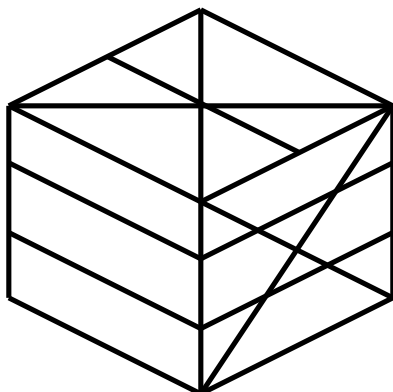

Figure 1

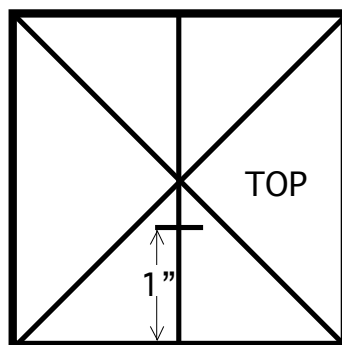

Figure 2

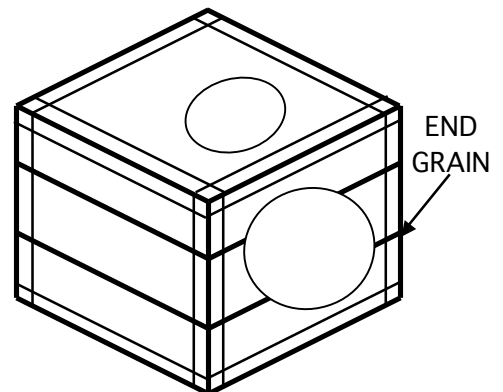

FIGURE 3

- 8) Check with Kuhn then center punch on marks made on steps 6 & 7.
- 9) On the top drill a 7/8" hole 1 inch deep on the DRILL PRESS #1.
- 10) On the side drill a 1 1/2" hole 1 3/4" deep on the DRILL PRESS #2.
- 11) Sand off all pencil marks.
- 12) On all the sides draw a line 1/8" away from each edge. **FIGURE 3**
- 13) Put In vice making sure you clamp the grain together
- 14) Get 1" Tap from Kuhn then thread the 7/8" hole.
- 15) File down each edge to the 1/8" line. Start with the end grain 1st.
- 16) Sand off all pencil marks.
- 17) Sand with 220 grit then 600 grit
- 18) Stain project put in locker.
- 19) Cut a piece of 1 inch dowel 3 1/4" long on the **BAND SAW**
- 20) Stamp your initials on one of the ends at table 5.
- 21) Drill 3/8" hole in the 1" dowel on the **DRILL PRESS**.
Sand with 200 grit then hand in 220 grit to get 600 grit.
- 22) Hand in 600 grit to get 3/8" piece of dowel.
- 23) Sand ends of 3/8" dowel to make it look like a pencil on both ends.
- 24) With a Hammer hit dowel into 3/8" hole in the 1 inch handle over hole in work bench.
- 25) Place handle in vice and cut threads with the 1" DIE.
- 26) Stain Handle let dry in locker.
- 27) Do evaluation. **EVALUATION MUST IN PENCIL**
- 28) Hand in Evaluation, Plans, and Nut Cracker to get project grade.